

Atera® SIGNO

Renault Trafic
Opel Vivaro

9/2001–
4/2001–

Nissan Prima Star

11/2002–

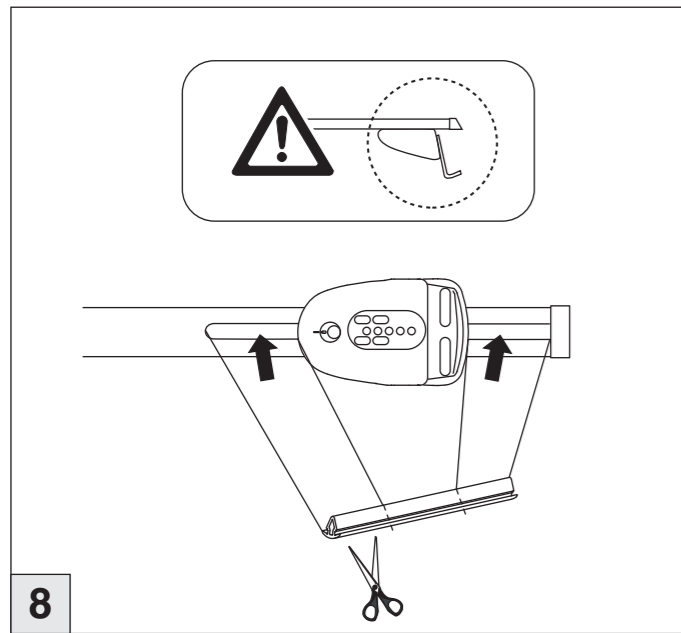

8

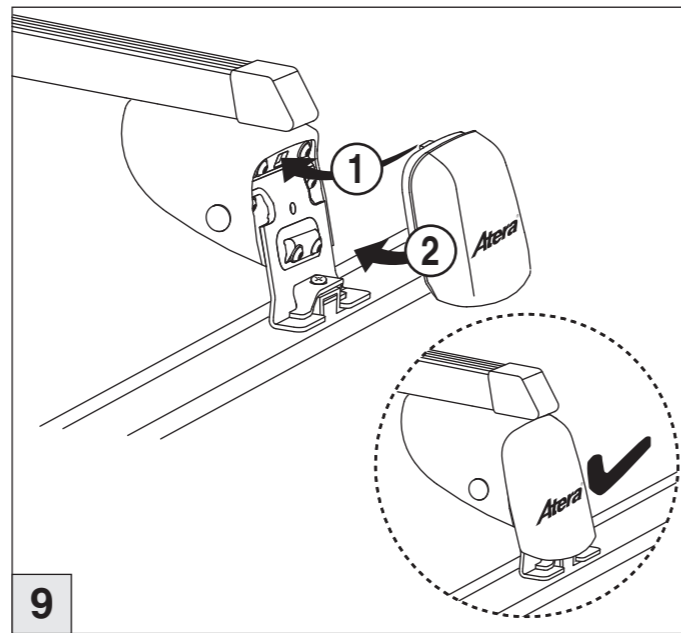

9

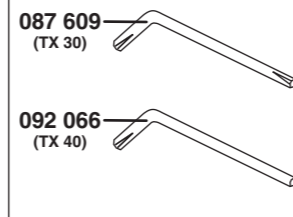
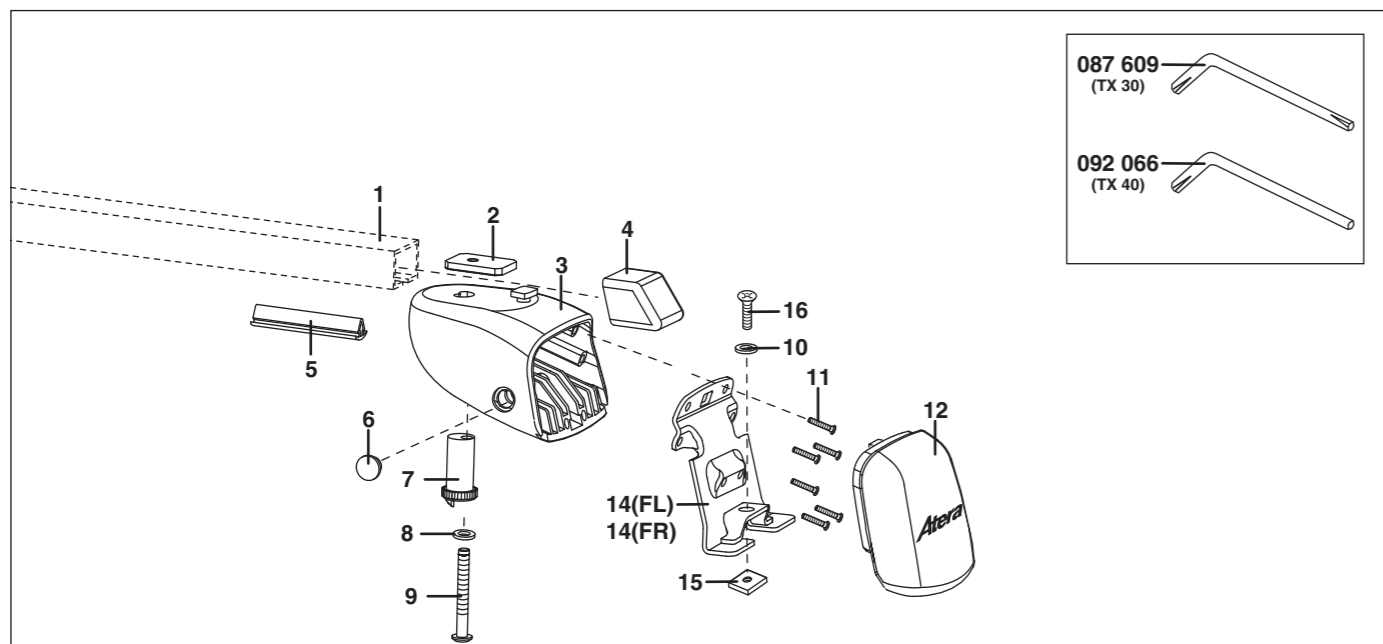

- | | | |
|---------------|-------------|-----------------|
| (1- 074 150*) | 7- 092 044 | 14(FL)- 093 467 |
| 2- 087 478 | 8- 087 886 | 14(FR)- 093 468 |
| 3- 092 683 | 9- 093 491 | 15- 093 438 |
| 4- 088 184 | 10- 087 879 | 16- 093 353 |
| 5- 092 043 | 11- 087 909 | |
| 6- 092 045 | 12- 092 037 | |

*Tragrohr nicht im Lieferumfang /crossbar not included

10

Atera
MADE IN GERMANY

Atera GmbH
Im Herrach 1
D-88299 Leutkirch
Servicetelefon: 0180-50 000 89
(14 ct/Min. aus dem dt. Festnetz)
E-Mail: info@atera.de

Atera® SIGNO

Renault Trafic

09/2001–

Opel Vivaro

04/2001–

Nissan Prima Star

11/2002–

Part-No. : 044 108

(Stützfußpaar für Tragrohr vorne /
pair of support legs for front crossbar)

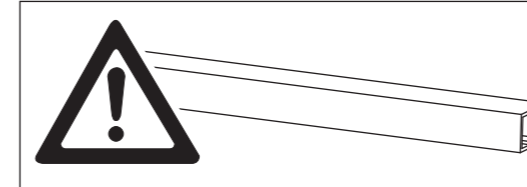
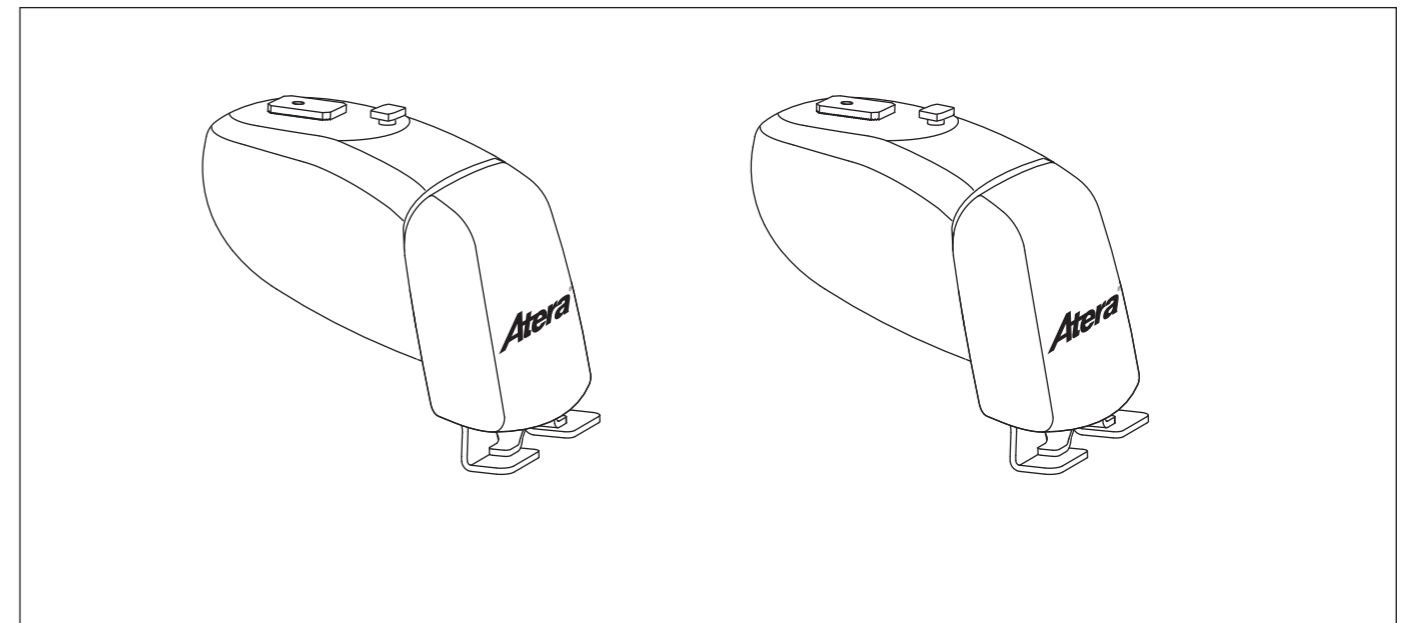

Stützfüße dürfen nur in Kombination mit original Atera-Tragrohren der Länge 1500 mm (Art.-Nr.: 074 150, nicht im Lieferumfang enthalten!) verwendet werden.
Supporting legs must be used only in combination with original carrier bars made by Atera with length of 1500 mm (Art. no.: 074 150, not included).

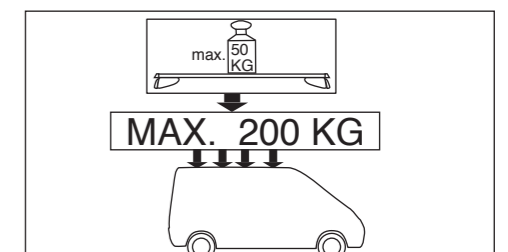
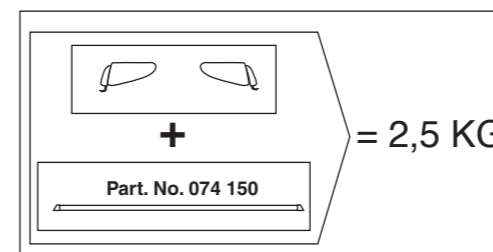

Atera® SIGNO

Renault Trafic
Opel Vivaro

9/2001–
4/2001–

Nissan Prima Star

11/2002–

Atera® SIGNO

Renault Trafic
Opel Vivaro

9/2001–
4/2001–

Nissan Prima Star

11/2002–

Tragrohr/cross bar (Part.No.= 074 150)

